



專利註冊紀錄冊  
REGISTER OF PATENTS

基本資料 Basic information

	狀況: Status:	根據條例第126(2)條, 專利停止有效 Patent ceased to have effect under S.126(2)
	專利類別: Patent Type:	短期專利 Short-term Patent
	專利編號: Patent No.:	HK1244177
[11]	發表編號: Publication No.:	HK1244177
[21]	申請編號: Application No.:	18104189.3
[54]	發明名稱: Title of Invention:	用於溝道型DMOS的集成堆疊在溝道中的防靜電網絡 INTEGRATED STACKED ESD NETWORK IN TRENCH FOR TRENCH DMOS
[51]	分類: Classified to:	H01L
	法律程序所用語文: Language of Proceedings:	英文 English

日期 Dates

[45]	批予專利日期: Patent Grant Date:	27-07-2018
[43]	專利說明書首次發表日期: Date of First Publication:	27-07-2018
[22]	提交日期: Filing Date:	27-03-2018

當事人 Parties

[71/73]	申請人/專利所有人: Applicant/ Proprietor:	蒙若賢 MONG, Yeuk Yin Unit 205, 2/F, Lakeside 1 No. 8 Science Park West Avenue Hong Kong Science Park Pak Shek Kok, N.T.
---------	--------------------------------------	--

HONG KONG

- [72] 發明人:  
Inventor: 蒙若賢
- MONG, Yeuk Yin  
Unit 205, 2/F, Lakeside 1  
No. 8 Science Park West Avenue  
Hong Kong Science Park  
Pak Shek Kok, N.T.  
HONG KONG黎茂林
- LAI, Mau Lam  
Unit 205, 2/F, Lakeside 1  
No. 8 Science Park West Avenue  
Hong Kong Science Park  
Pak Shek Kok, N.T.  
HONG KONG周德光
- CHAU, Duc Quang  
Unit 205, 2/F, Lakeside 1  
No. 8 Science Park West Avenue  
Hong Kong Science Park  
Pak Shek Kok, N.T.  
HONG KONG
- [74] 代理人:  
Agent: HONG KONG INTELLECTUAL PROPERTY AGENT LIMITED  
Unit 230, 2/F, Building 12W  
No. 12 Science Park West Avenue  
Phase 3, Hong Kong Science Park  
Pak Shek Kok, N.T., HONG KONG
- [74] 送達地址:  
Address for Service: HONG KONG INTELLECTUAL PROPERTY AGENT LIMITED  
Unit 230, 2/F, Building 12W  
No. 12 Science Park West Avenue  
Phase 3, Hong Kong Science Park  
Pak Shek Kok, N.T., HONG KONG

續期 Renewal

下次續期日期: 27-03-2022

Next Renewal due date:

未繳交續期費致專利失效日期: 27-03-2022

Date not in Force due to non-

payment of Renewal Fee:

# INTEGRATED STACKED ESD NETWORK IN TRENCH FOR TRENCH DMOS

## FIELD OF THE INVENTION

The present invention relates to Trench Double-diffused Metal-Oxide-Semiconductor Field Effect Transistor (hereinafter “Trench DMOS”), and more particularly to ESD (Electrostatic Discharge) protection for Trench DMOS.

## BACKGROUND OF THE INVENTION

ESD is a common cause of failure in solid state electronic components during manufacturing. High ESD voltage can cause damage to the Gate oxide in Trench DMOS, leading to instant failure or secondary failure. ESD protection in component level is essential to prevent such damage.

A pair or several pairs of back to back PN diodes are often used to divert the high ESD charges away before the voltage is high enough to damage the Gate oxide. Since technology keeps advancing, the Die size of Trench DMOS is shrinking and the intrinsic ESD capability is also shrinking. A single stage of ESD diodes is not adequate and two stages of ESD diodes with resistor in between are often required to handle higher ESD voltage.

Usually in Trench DMOS, ESD structure is formed in the poly layer at Gate pad. In modern contact on trench process, a layer of poly on top of silicon surface means extra topology, which makes masking layer like contact masking difficult. Also two stages of ESD diodes with resistor in between need complicated layout and metal routing.

## SUMMARY OF THE INVENTION

For the defects in the prior art, an object of the present invention is to provide a stacked ESD network placed inside the trench which offers good ESD protection capability, flat topology and simple metal routing.

The technical solutions of the present invention are as follows:

In one aspect, a stacked ESD structure is provided, which comprises: a heavily doped substrate acting as a drain; an epitaxial layer grown on the substrate; a trench formed in the epitaxial layer; an oxide layer formed on an inner sidewall of the trench; a first poly layer formed in the trench; a plurality of P-type regions and N-type regions formed inside the first poly layer to make back to back diodes in the first poly layer; a dielectric layer formed in the trench, on top of the first poly layer; a second poly layer formed in the trench, on top of the dielectric layer; a plurality of P-type regions and N-type regions formed inside the second poly layer to make back to back diodes and poly

resistors in the second poly layer; an insulating layer formed on top of the second poly layer and the trench; a plurality of contact defined to connect the first poly layer, the poly resistor and the second poly layer, through the insulating layer; and a metal layer formed on top of the insulating layer.

Advantageously, a thickness of the epitaxial layer is about 2~50  $\mu\text{m}$ .

Advantageously, the oxide layer covers a bottom and sidewalls of the trench.

Advantageously, the first poly layer is un-doped and the first poly layer is inside the trench.

Advantageously, blanket ESD implant and masked N<sup>+</sup> implant are used to form the back to back diodes in the first and second poly layers.

Advantageously, the number of pair of ESD back to back diodes in each poly layer is one; or the number pair of ESD back to back diodes in series is more than one; the number of pair of ESD back to back diodes can be the same or different in the first and second poly layers.

Advantageously, the dielectric layer is oxide or nitride or composite of both material, and a thickness of the dielectric layer is about 0.2~1 $\mu\text{m}$

Advantageously, the second poly layer is un-doped and the second poly layer is also inside the trench.

Advantageously, the stack of first poly layer and second poly layers are inside the trench.

Advantageously, the poly resistor is in stripe form with one or two sides connected to the second poly layer and is defined in the center of the second poly layer.

Advantageously, the insulating layer is a layer of borophosphosilicate glass or a composite layer of un-doped silicate glass and borophosphosilicate glass.

Advantageously, the source contact of the first poly layer and the second poly layer can be defined at one side or more than one side.

Advantageously, simple metal routing is needed to connect two stages of ESD back to back diodes with resistors.

In another aspect, a method for preparing the stacked ESD structure is provided, which comprises: providing a heavily doped substrate acting as a drain; growing an epitaxial layer on the substrate; forming a trench in the epitaxial layer; forming an oxide layer on an inner sidewall of the trench; forming a first poly layer in the trench; forming a plurality of P-type regions and N-type regions inside the first poly layer to make back to back diodes in the first poly layer; forming a dielectric layer in the trench, on top of the first poly layer; forming a second poly layer in the trench, on top of the dielectric layer; forming a plurality of P-type regions and N-type regions inside the second poly layer to make back to back diodes and poly resistors in the second poly layer; forming an insulating layer on top of the second poly layer and the trench; defining a plurality of contact to connect the first poly layer, the poly resistor and the second poly layer, through the insulating layer; and forming a metal layer on top of the insulating layer.

Advantageously, the first poly layer is un-doped and the first poly layer is inside the trench.

Advantageously, blanket ESD implant and masked N<sup>+</sup> implant are used to form the back to back diodes in the first and second poly layers.

Advantageously, the second poly layer is un-doped and the second poly layer is also inside the trench.

Advantageously, the stack of first poly layer and second poly layers are inside the trench.

Advantageously, the poly resistor is in stripe form with one or two sides connected to the second poly layer and is defined in the center of the second poly layer.

The stacked ESD network placed inside the trench offers good ESD protection capability, flat topology and simple metal routing.

### BRIEF DESCRIPTION OF THE DRAWINGS

FIG. 1 is a cross section view of a stacked ESD structure according to a first embodiment of the present invention;

FIG. 2 is a three dimensional view of the stacked ESD structure according to the first embodiment of the present invention;

FIGS. 3-15 show steps of making the stacked ESD structure in FIG. 1 in cross-section view;

FIGS. 16-22 show some of the steps of making the stacked ESD structure in FIG. 1 in top view;

FIG. 23 is a schematic diagram of a two-stage ESD structure.

### DETAILED DESCRIPTION OF THE EMBODIMENTS

The present invention will now be more particularly described, by way of example only, with reference to the accompanying drawings. It should be understood that the drawing are for better understanding and should not limit the present invention. Dimensions of components and features shown in the drawings are generally chosen for convenience and clarity of presentation and are not necessarily shown to scale.

Referring to FIGS. 1 and 2, a stacked ESD structure according to a first embodiment of the present invention includes a substrate 102 and an epitaxial layer 104 grown on the substrate 102. The substrate 102 acts as a drain of the trench DMOS, which is N-type or P-type semiconductor and heavily doped. The epitaxial layer 104 is the same type semiconductor as the substrate and lightly doped. A thickness of the epitaxial layer 104 is usually 2~50  $\mu\text{m}$ .

The stacked ESD structure further includes a trench 106 defined in the epitaxial layer 104 and at the Gate pad area, and an oxide layer 108 formed in the trench 106, covering the bottom and sidewalls of the trench 106.

The stacked ESD structure further includes a first poly layer 110 formed in the trench 106, a

plurality of P-type regions 122a and N-type regions 122b formed inside the first poly layer 110 as shown in FIG. 16 to make back to back diodes in the first poly layer 110. The first poly layer 110 is un-doped and the first poly layer 110 is inside the trench. Blanket ESD implant and masked N+ implant are used to form the ESD diodes.

The stacked ESD structure further includes a dielectric layer 112 formed in the trench 106, on top of the first poly layer 110. The dielectric layer 112 can be oxide or nitride or composite of both materials. The thickness of the dielectric layer 112 is usually 0.2~1  $\mu\text{m}$ .

The stacked ESD structure further includes a second poly layer 114 formed in the trench 106, on top of the dielectric layer 112, a plurality of P-type regions 124a and N-type regions 124b formed inside the second poly layer 114 as shown in FIG. 17 to make back to back diodes. This back to back ESD diode directly connects to poly resistors 126 in the second poly layer 114. The second poly layer 114 is un-doped and the top of the second poly layer 114 is not higher than the top of the trench 106. Blanket ESD implant and masked N+ implant are used to form the ESD diodes. The poly resistor 126 is defined in the center of the second poly layer. Depending on design specification, the poly resistor 126 could be in stripe form with one or two sides connected to the second poly layer 114.

The stacked ESD structure further includes an insulating layer 116 formed on the surface of the epitaxial layer 104 and covering the trench 106. The insulating layer 116 is usually BPSG (Borophosphosilicate glass) or composite of USG (Undoped Silicate Glass) and BPSG. As shown in FIGS. 1, 2 and 18, Contact holes 118 are defined in the insulating layer 116 and extend to the poly resistor 126, the second poly layer 114 and the first poly layer 110.

The stacked ESD structure may further includes a metal layer 120 formed on the insulating layer 116. The metal layer 120 fills into the contact holes 118, which connects to the poly resistors 126 and the first poly layer 110 to the Gate terminal, and connects the other end of the second poly layer 114 and the other end of the first poly layer 110 to the Source terminal as shown in FIG. 18.

An example method to form the present ESD structure integrated in trench DMOS will be described in detail as follows.

Firstly, as shown in FIG. 1 a heavily doped N-type substrate 102 is provided and an N-type epitaxial layer 104 is grown on a surface of the substrate 102. As shown in FIG. 3, a first mask is then used to define a trench pattern. Silicon etch is employed to etch the epitaxial layer 104 to a pre-defined depth to form the trench 106 for ESD structure 100 and the trench 206 in cell area 200.

As shown in FIG. 4, a gate oxide layer 108 is then formed in the trenches 106 and 206. As shown in FIG. 5, A first poly layer 110, which is un-doped, is then deposited and etched back as shown in FIG. 6. As shown in FIG. 7, a light P-type region is formed by blanket implanting light P-type impurity into the first poly layer 110. A masked body region is formed by implanting P-type

impurity into the epitaxial layer in the cell area 200 between the cell trenches 206. A heavy N-type region is formed by masked implanting heavy N-type impurity into the first poly layer 110, thus forming back to back diodes in the first poly layer 110, and into the epitaxial layer 104 between the cell trenches 206 in the cell area 200.

As shown in FIGS. 8 and 9, an insulating layer 112 is then deposited to cover the epitaxial layer 104 and the trenches 106 and 206. As shown in FIG. 10, A second poly layer 114, which is un-doped, is then deposited on the insulating layer 112. As shown in FIG. 11, a light P-type region is formed by blanket implanting light P-type impurity into the second poly layer 114 and a heavy N-type region is formed by masked implanting heavy N-type impurity into the second poly layer 114, thus forming back to back diodes and the poly resistors 126 in the second poly layer 114.

As shown in FIG. 11, a mask is used to define the second poly layer pattern, thus separating the back to back diodes and the poly resistor 126 in x-direction. As shown in FIG. 12, an insulating layer 116 is formed on the surface of the epitaxial layer 104 and covers the trenches 106 and 206. The insulating layer 116 is usually BPSG (Borophosphosilicate glass) or composite of USG (Undoped Silicate Glass) and BPSG. As shown in FIG. 13, a contact mask is used to define contact holes 118 in the insulating layer 116 and extend to the poly resistor 126, the second poly layer 114 and the first poly layer 110 in the ESD structure 100, and to the body region in cell area 200. Removing the oxide in the contact holes 118, the contact holes 118 reach the poly resistor 126, the second poly layer 114 and the first poly layer 110 in the ESD structure 100, and to the body region in cell area 200.

As shown in FIG. 13, P+ dopant is then implanted into the body region via the contact holes 118 to form a P+ body pickup region. Finally, as shown in FIG. 1, a metal layer 120 is deposited over the insulating layer 116 and fills up the contact holes 118 as shown in FIG. 14. As shown in FIG. 15, a metal mask is used to define the source and gate pad regions in the metal layer 120. The Gate metal 120a connects one side of the poly resistors 126 and one side of the first poly layer 110. The Source metal 120b connects the other side of the second poly layer 114 and the other side of the first poly layer 110.

Notably, some of the reference numbers in FIGS. 3-15 have been omitted for a better view to the structure. The reference numbers omitted in FIGS. 3-15 have been shown in FIG. 1. One of ordinary skill in the art can refer to FIG. 1 for a better understand to FIGS. 3-15.

Some of above steps for making the stacked ESD structure is also shown in FIGS. 16-22 in top view. FIGS. 16-22 are provided here for better understanding of the structure shown in FIG. 1.

As an example, FIG. 23 shows a schematic diagram of a two-stage ESD structure.

Although the invention is described with reference to one or more preferred embodiments, it should be appreciated by those skilled in the art that various modifications are possible. Therefore, the scope of the invention is to be determined by reference to the claims that follow.



We claim:

1. A stacked ESD structure, comprising:
  - a heavily doped substrate acting as a drain;
  - an epitaxial layer grown on the substrate;
  - a trench formed in the epitaxial layer;
  - an oxide layer formed on an inner sidewall of the trench;
  - a first poly layer formed in the trench;
  - a plurality of P-type regions and N-type regions formed inside the first poly layer to make back to back diodes in the first poly layer;
  - a dielectric layer formed in the trench, on top of the first poly layer;
  - a second poly layer formed in the trench, on top of the dielectric layer;
  - a plurality of P-type regions and N-type regions formed inside the second poly layer to make back to back diodes and poly resistors in the second poly layer;
  - an insulating layer formed on top of the second poly layer and the trench;
  - a plurality of contact defined to connect the first poly layer, the poly resistor and the second poly layer, through the insulating layer; and
  - a metal layer formed on top of the insulating layer.
2. The stacked ESD structure of claim 1, wherein, a thickness of the epitaxial layer is about 2~50  $\mu\text{m}$ .
3. The stacked ESD structure of claim 1, wherein the oxide layer covers a bottom and sidewalls of the trench.
4. The stacked ESD structure of claim 1, wherein the first poly layer is un-doped and the first poly layer is inside the trench.
5. The stacked ESD structure of claim 1, wherein blanket ESD implant and masked N+ implant are used to form the back to back diodes in the first and second poly layers.
6. The stacked ESD structure of claim 1, wherein the number of pair of ESD back to back diodes in each poly layer is one; or the number pair of ESD back to back diodes in series is more than one; the number of pair of ESD back to back diodes can be the same or different in the first and second poly layers.
7. The stacked ESD structure of claim 1, wherein the dielectric layer is oxide or nitride or composite of both material, and a thickness of the dielectric layer is about 0.2~1  $\mu\text{m}$
8. The stacked ESD structure of claim 1, wherein the second poly layer is un-doped and the second poly layer is also inside the trench.
9. The stacked ESD structure of claim 1, the stack of first poly layer and second poly layers

are inside the trench.

10. The stacked ESD structure of claim 1, wherein the poly resistor is in stripe form with one or two sides connected to the second poly layer and is defined in the center of the second poly layer.

11. The stacked ESD structure of claim 1, wherein the insulating layer is a layer of borophosphosilicate glass or a composite layer of un-doped silicate glass and borophosphosilicate glass.

12. The stacked ESD structure of claim 1, wherein the source contact of the first poly layer and the second poly layer can be defined at one side or more than one side.

13. The stacked ESD structure of claim 1, wherein simple metal routing is provided to connect two stages of ESD back to back diodes with resistors.

14. A method for preparing the stacked ESD structure of claim 1, comprising:

providing a heavily doped substrate acting as a drain;

growing an epitaxial layer on the substrate;

forming a trench in the epitaxial layer;

forming an oxide layer on an inner sidewall of the trench;

forming a first poly layer in the trench;

forming a plurality of P-type regions and N-type regions inside the first poly layer to make back to back diodes in the first poly layer;

forming a dielectric layer in the trench, on top of the first poly layer;

forming a second poly layer in the trench, on top of the dielectric layer;

forming a plurality of P-type regions and N-type regions inside the second poly layer to make back to back diodes and poly resistors in the second poly layer;

forming an insulating layer on top of the second poly layer and the trench;

defining a plurality of contact to connect the first poly layer, the poly resistor and the second poly layer, through the insulating layer; and

forming a metal layer on top of the insulating layer.

15. The method of claim 10, wherein the first poly layer is un-doped and the first poly layer is inside the trench.

16. The method of claim 10, wherein blanket ESD implant and masked N<sup>+</sup> implant are used to form the back to back diodes in the first and second poly layers.

17. The method of claim 10, wherein the second poly layer is un-doped and the second poly layer is also inside the trench.

18. The method of claim 10, wherein the stack of first poly layer and second poly layers are inside the trench.

19. The method of claim 10, wherein the poly resistor is in stripe form with one or two sides connected to the second poly layer and is defined in the center of the second poly layer; or the poly resistor is in circular shape, formed as a part of the second poly layer.

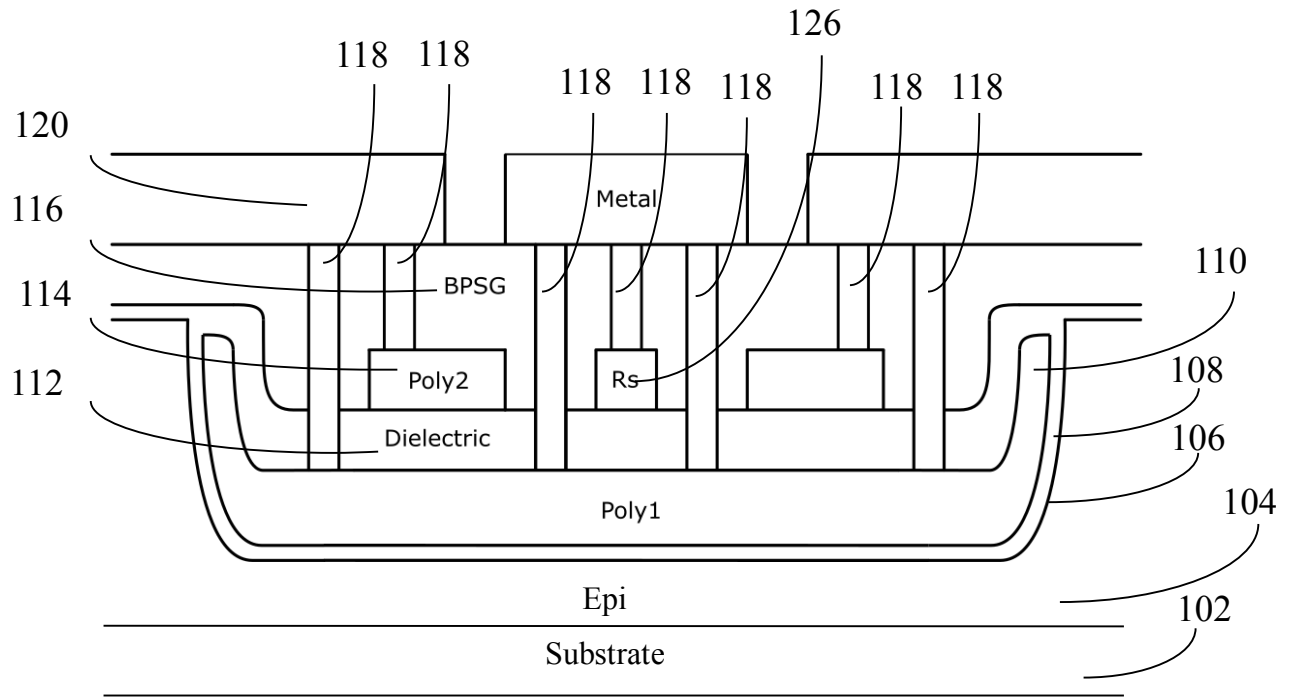

FIG. 1

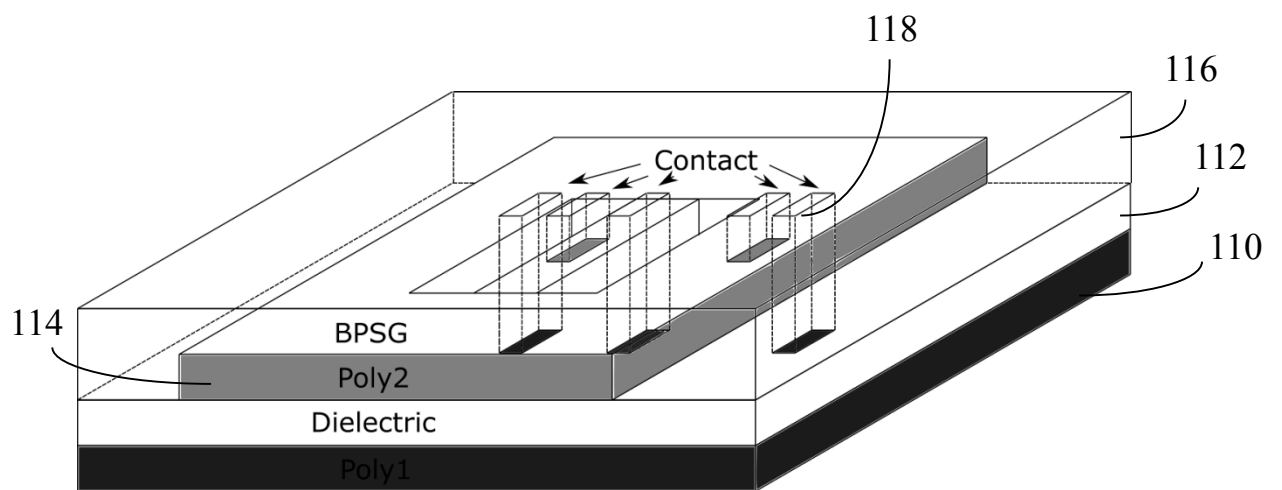

FIG. 2

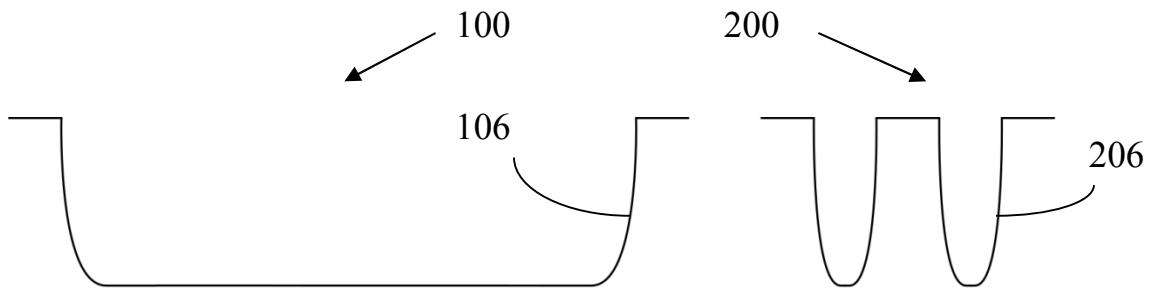

FIG. 3

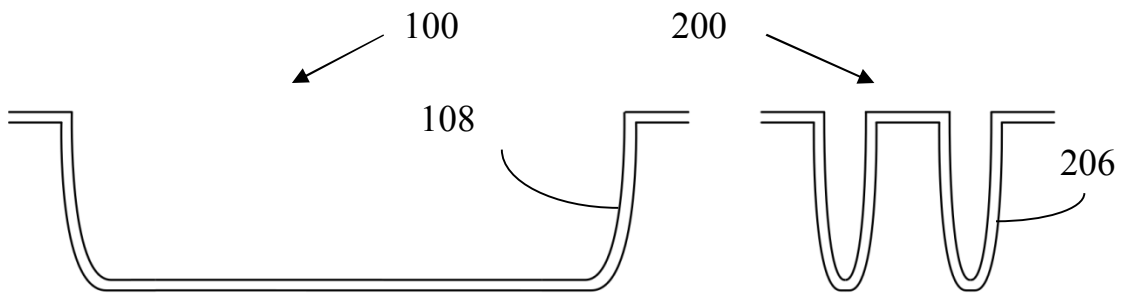

FIG. 4

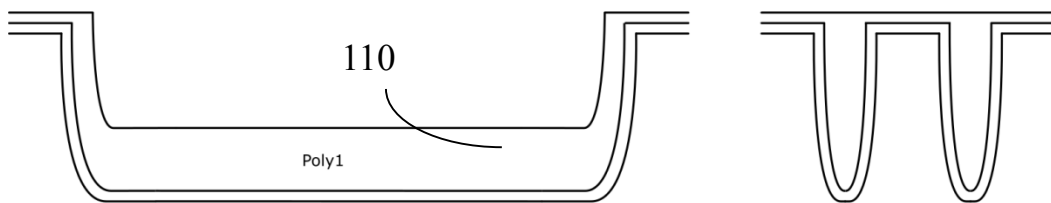

FIG. 5

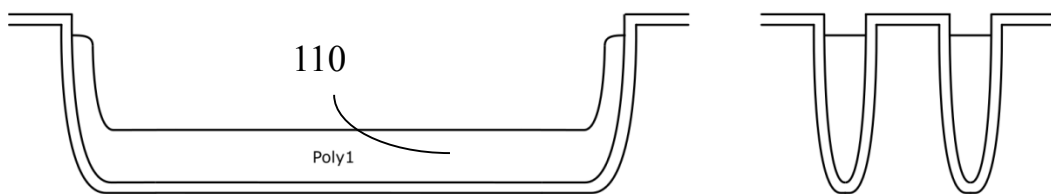

FIG. 6

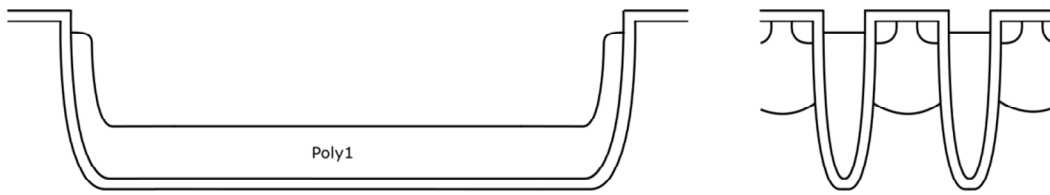

FIG. 7

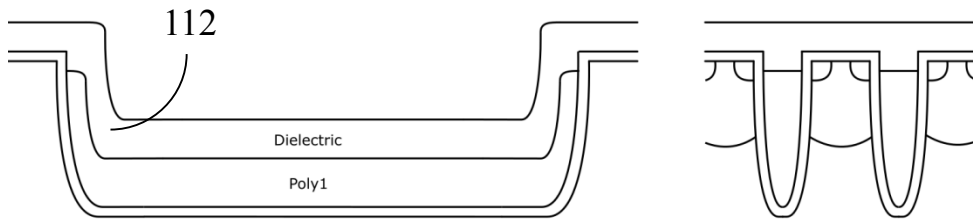

FIG. 8

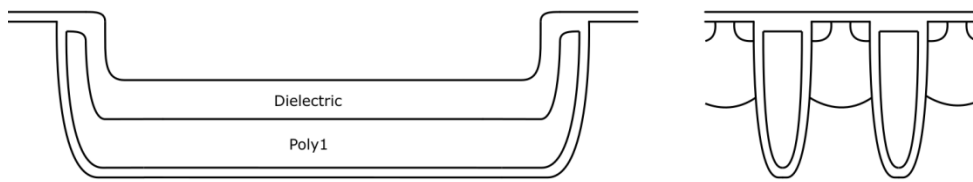

FIG. 9

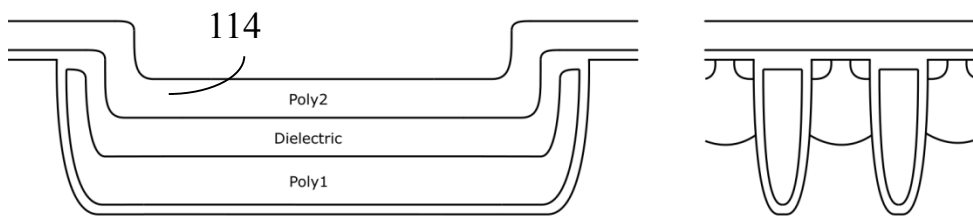

FIG. 10

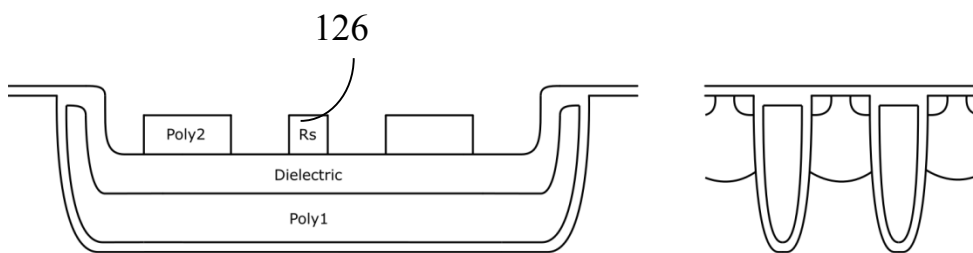

FIG. 11

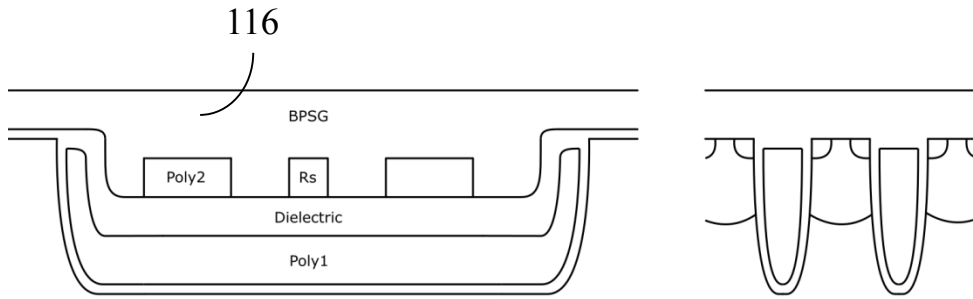

FIG. 12

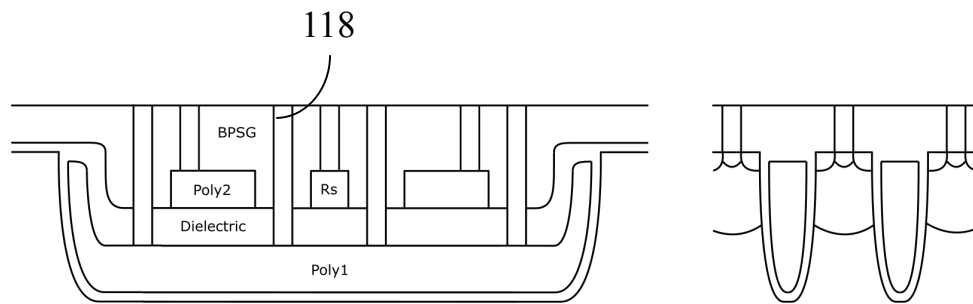

FIG. 13

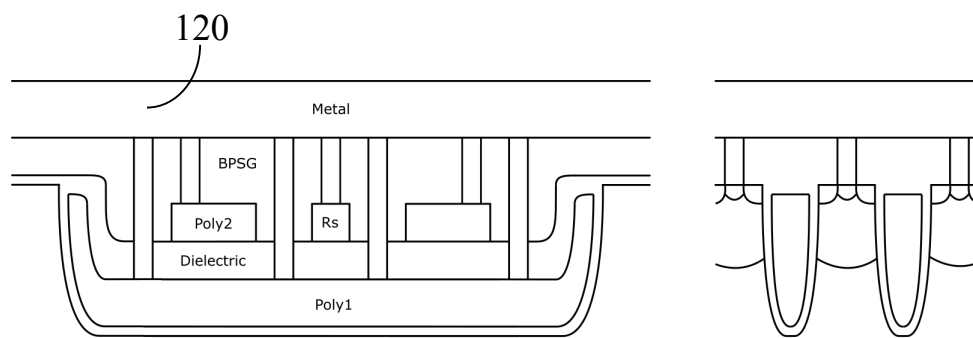

FIG. 14

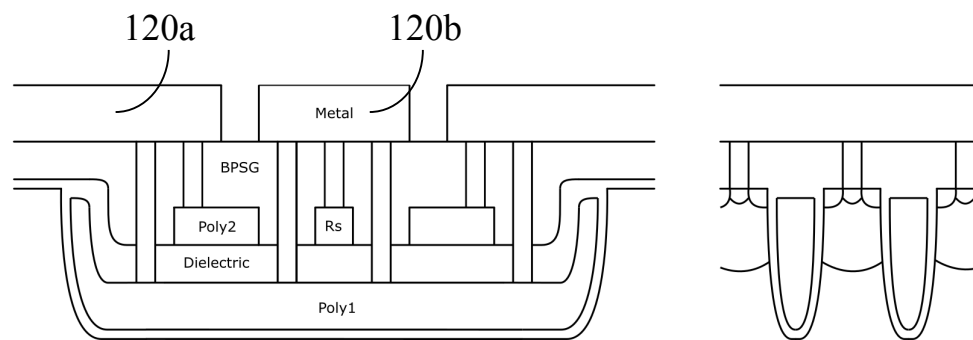

FIG. 15

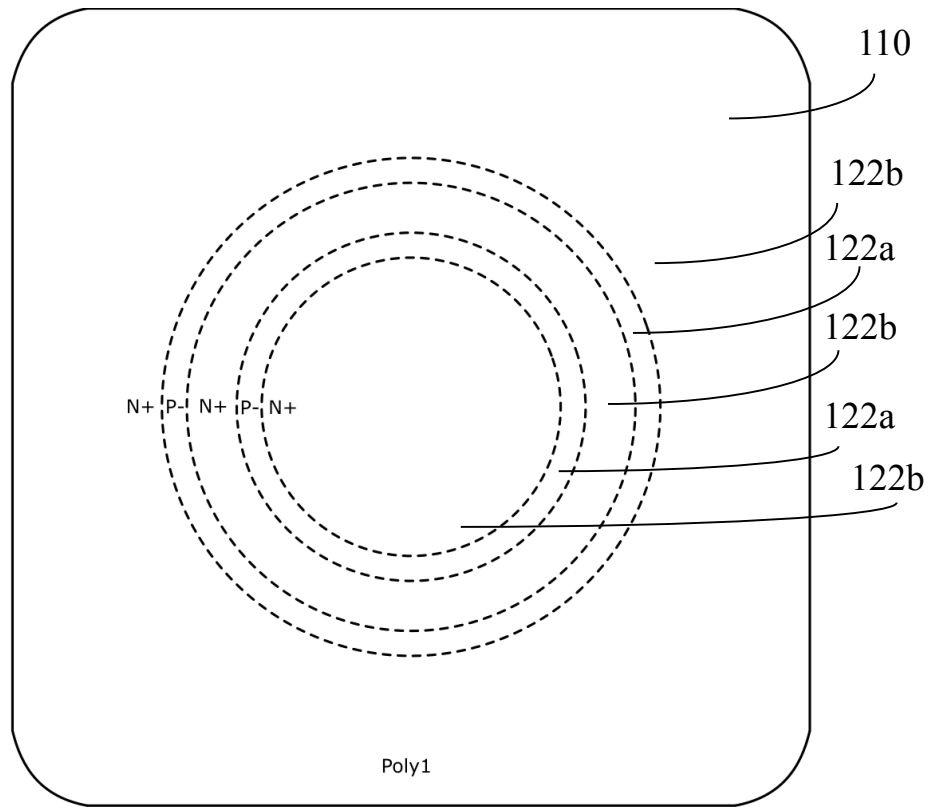

FIG. 16

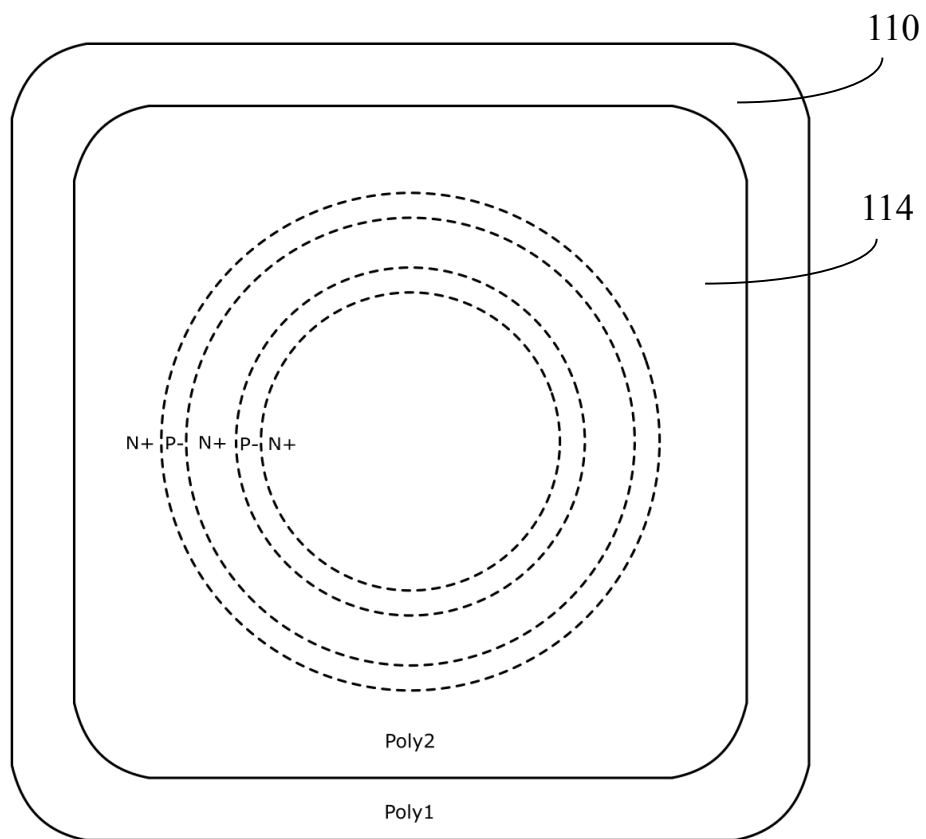

FIG. 17



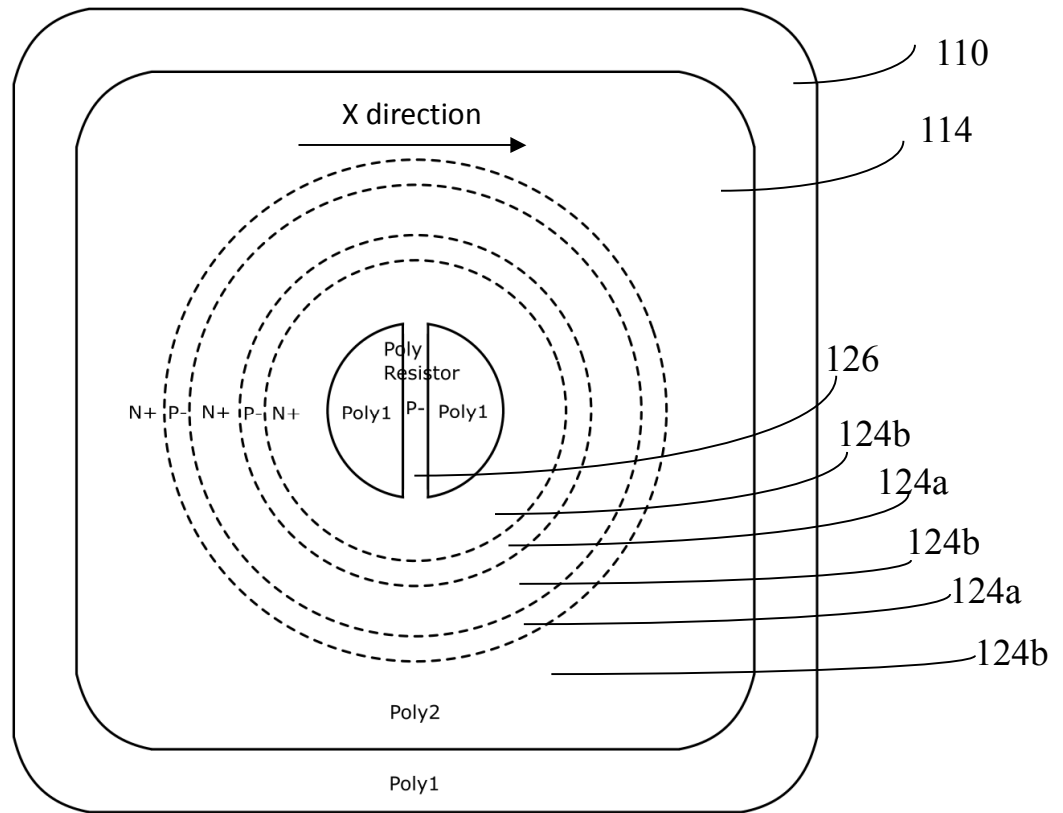

FIG. 18

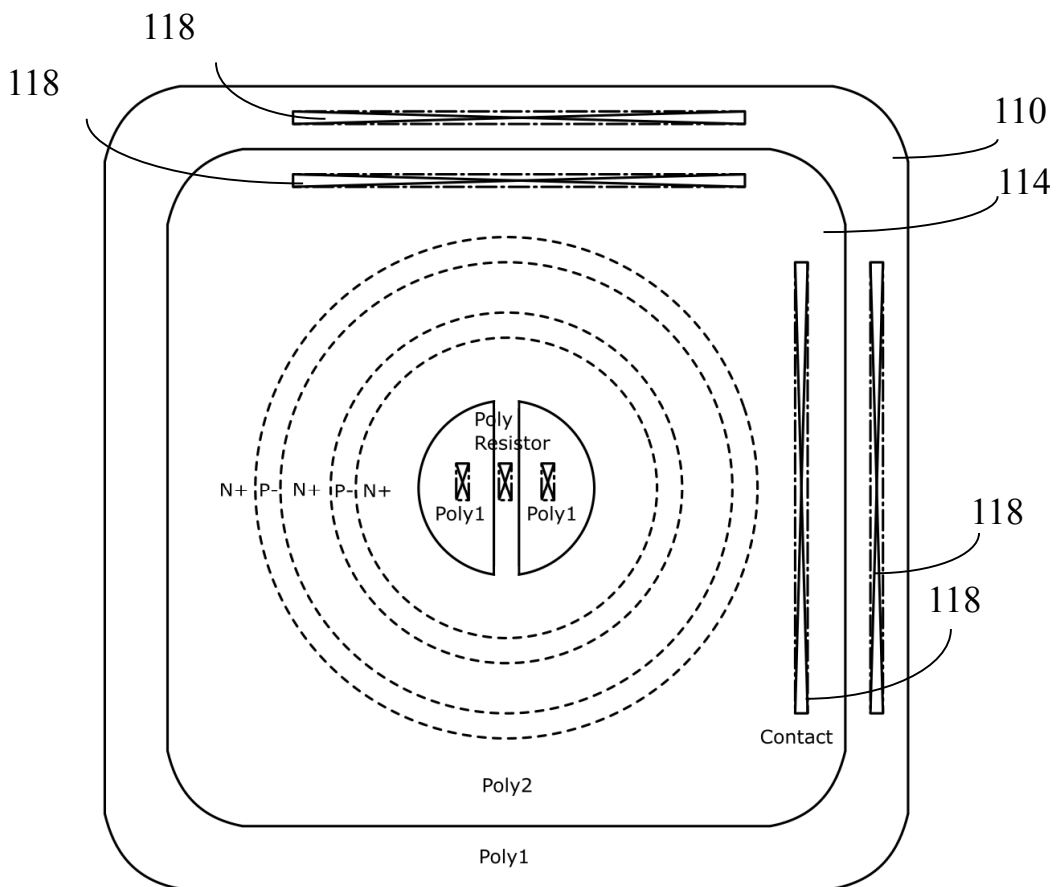

FIG. 19

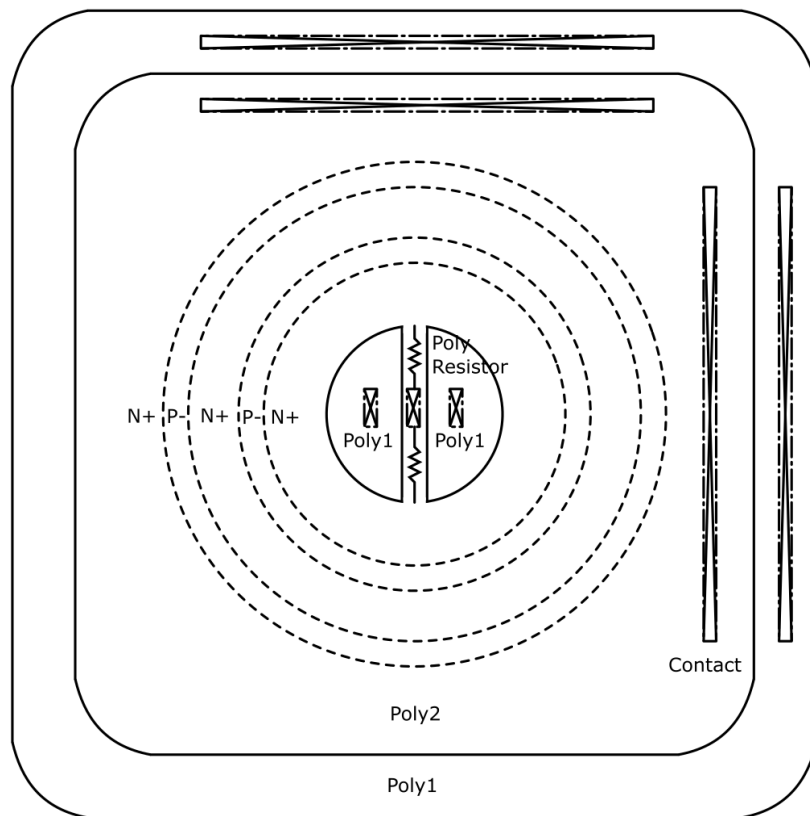

FIG. 20

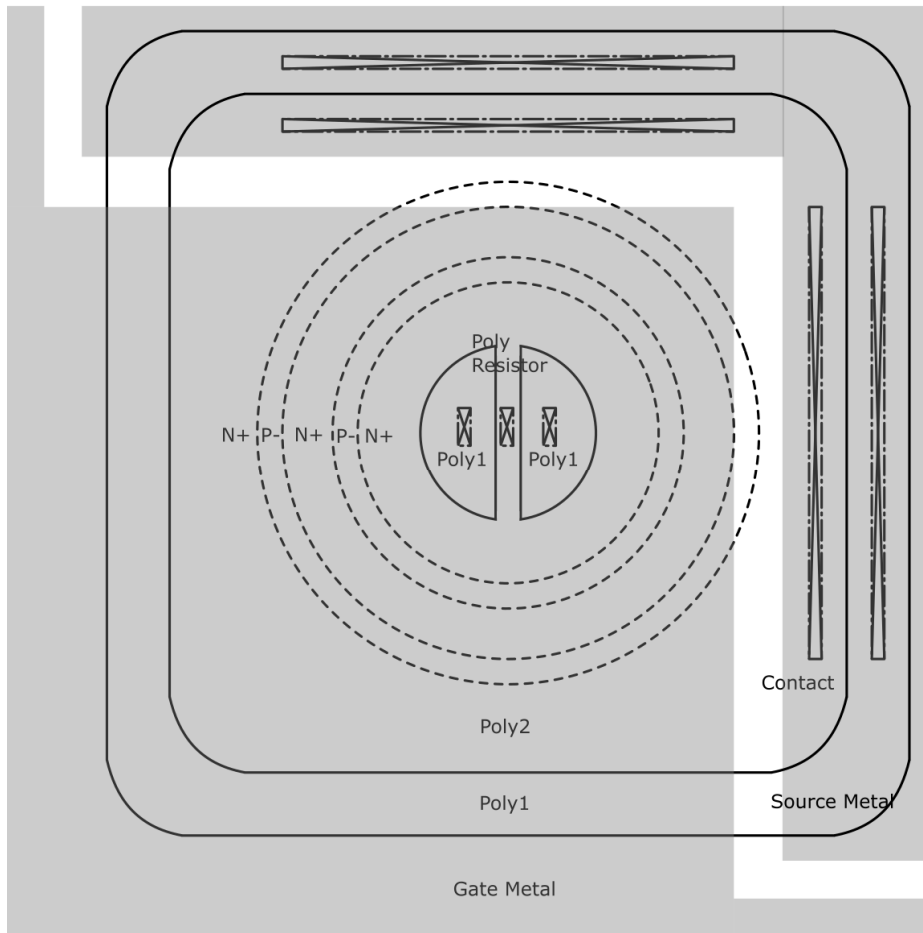

FIG. 21

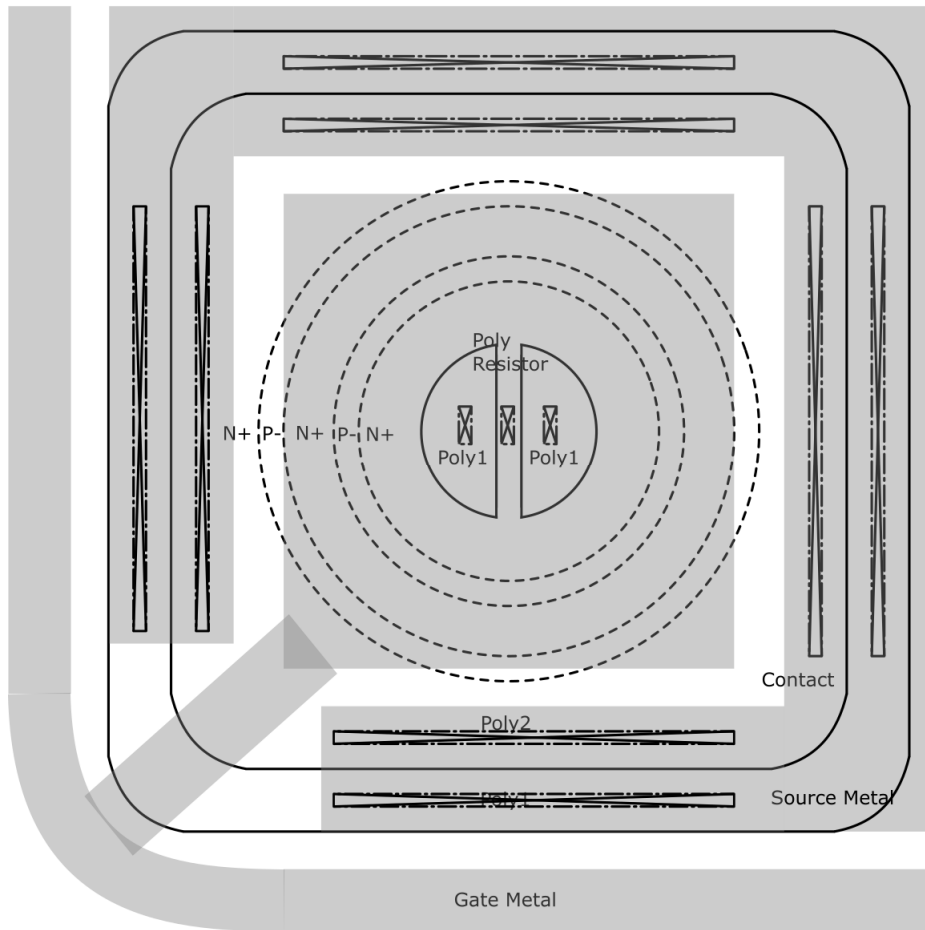

FIG. 22

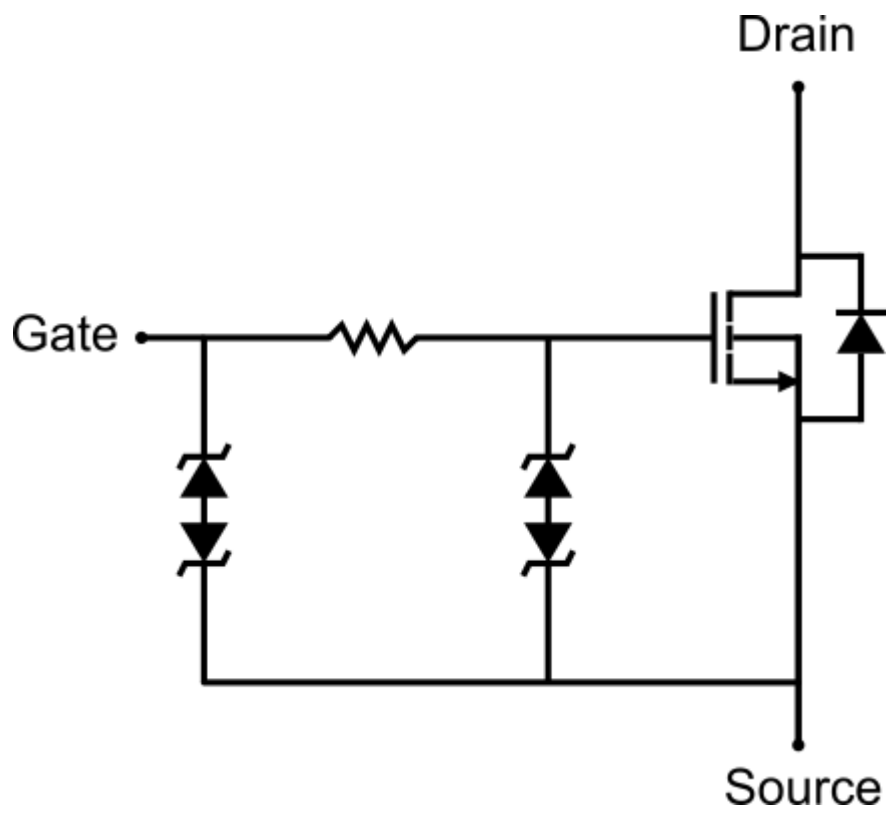

FIG. 23